



Tensioner EN
Installation instructions

Spannstange DE
Montageanleitung

Tendeur de toile FR
Instructions de montage

Barra de tensión ES
Instrucciones de montaje

Tenditelo IT
Istruzioni di montaggio

Please consult the website for
instructions in the languages:

NL-SV-DA-NO-FI-PT

BG-EL-ET-HR-HU-LT

LV-PL-RO-SK-SL



8 004815 426637

RAFTER
F40van

98655Z134



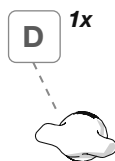
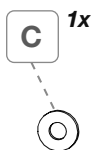
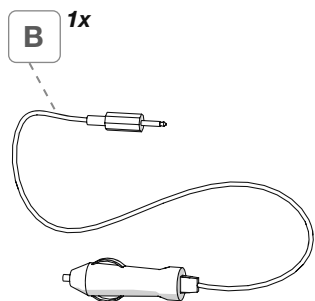
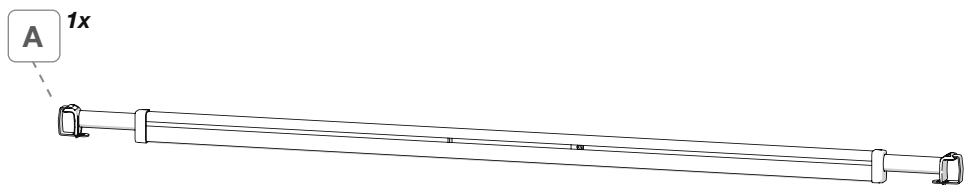

12Vdc - 6,4 W/m - 0,53 A - IP65 - CRI > 85

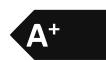

Package contents / Verpackungsinhalt / Contenu de l'emballage / Contenido del embalaje / Contenuto dell'imballo **p. 2**

Installation instructions / Montageanleitung / Instructions de montage / Instrucciones de montaje / Istruzioni di montaggio **p. 3**

Safety instructions / Sicherheitshinweise / Consignes de sécurité / Instrucciones de seguridad / Avvertenze di sicurezza **p. 7**

Warranty / Garantie / Garantie / Garantía / Garanzia **p. 10**



EN

Check that nothing has been damaged or deformed during transport. In the event of doubts or questions concerning the installation, use or limitations of the product, contact the dealer. We recommend that the installation is carried out by qualified personnel and in compliance with current local regulations.

DE

Bitte kontrollieren Sie, dass alle Einzelteile einwandfrei sind und nicht während dem Transport beschädigt wurden. Im Zweifelsfall oder bei Fragen zur Montage, Verwendung oder zu Einschränkungen des Produkts wenden Sie sich bitte an Ihren Händler. Wir empfehlen die Anbringung durch Fachpersonal in Übereinstimmung mit den geltenden lokalen Vorschriften vornehmen zu lassen.

FR

Contrôler le contenu du colis et vérifier qu'aucune pièce n'ait été cassée ou déformée durant le transport. En cas de doutes ou de questions relatives à l'installation, l'utilisation du produit, contactez votre concessionnaire. L'installation doit être réalisée par des personnes dûment qualifiées et conformément aux normes en vigueur dans le pays d'installation.

ES

Controlar que ningún detalle se haya roto o deformado durante el transporte. En caso de dudas o si tiene alguna pregunta sobre el montaje, uso y limitaciones del producto, póngase en contacto con el distribuidor. Recomendamos que la instalación se realice por personal cualificado en conformidad con las regulaciones locales.

IT

Controllare che nessun particolare sia rotto o deformato a causa di errori di trasporto. In caso di dubbi o domande relative al montaggio, utilizzo e limiti del prodotto, contattare il rivenditore. Consigliamo di far eseguire l'installazione da parte di personale qualificato ed in conformità alle vigenti normative locali.

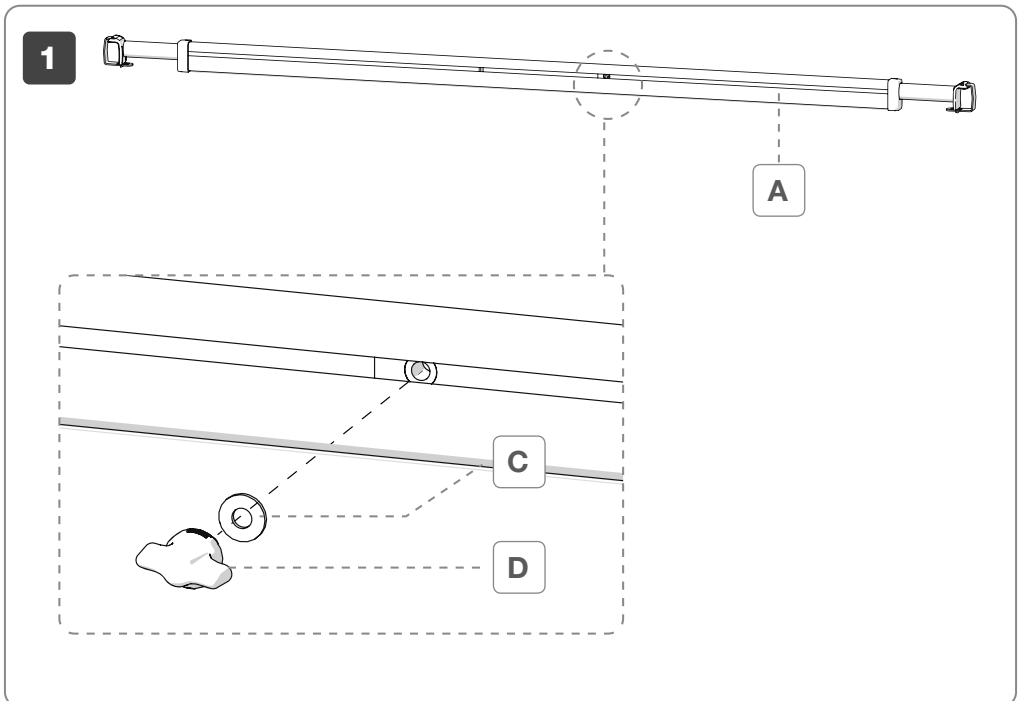

2

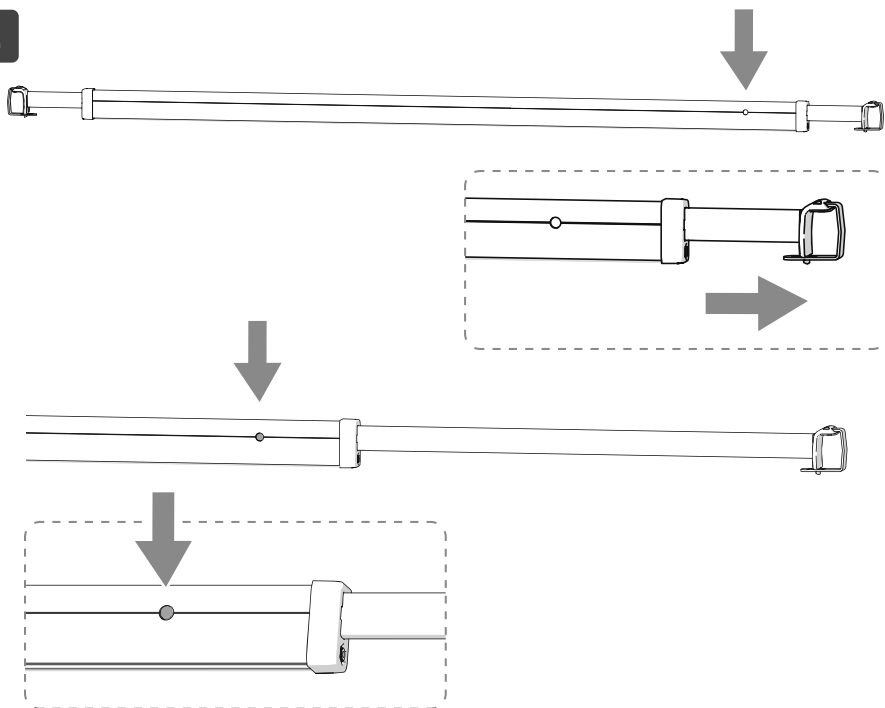

3

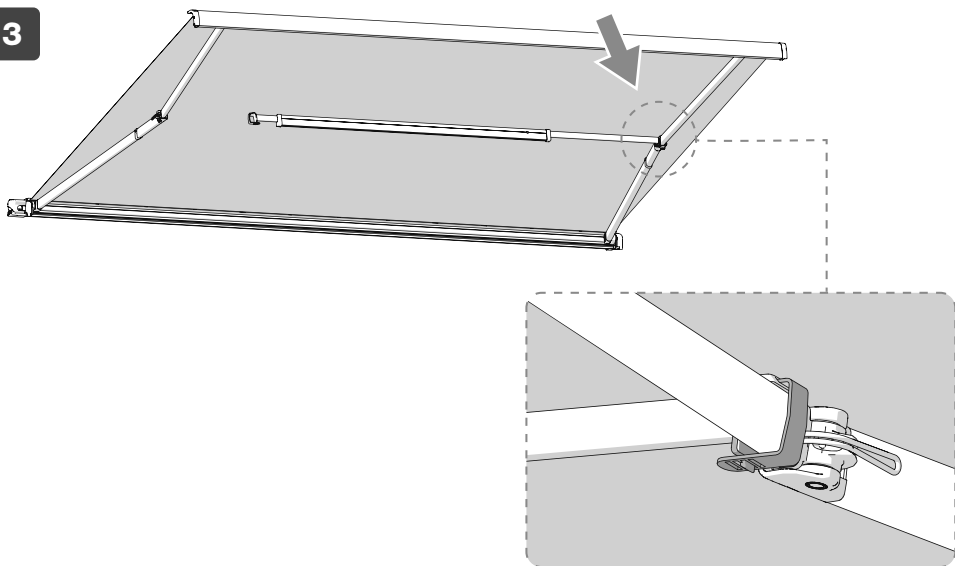

4

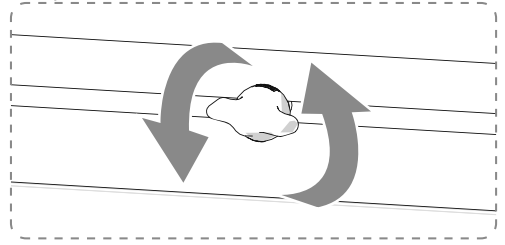
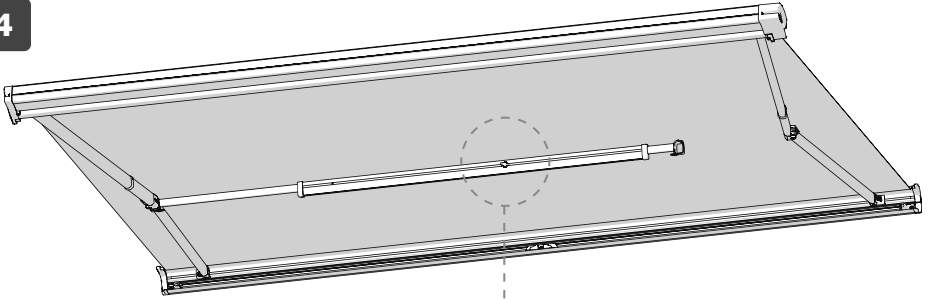

5

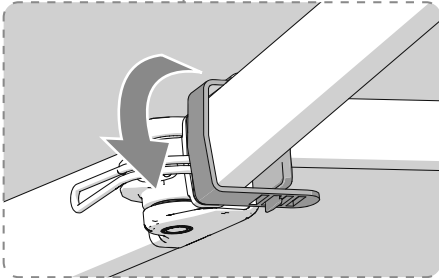
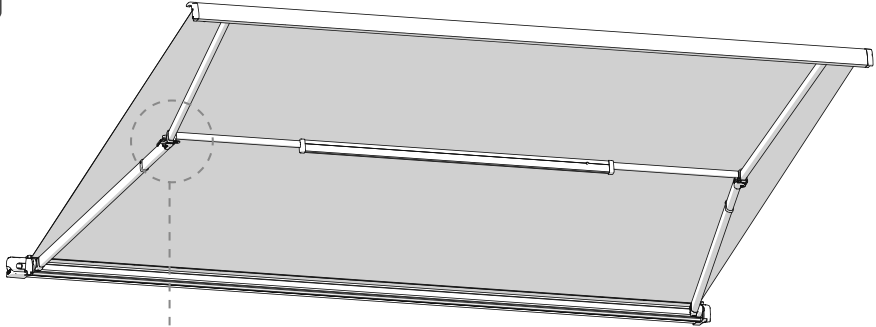

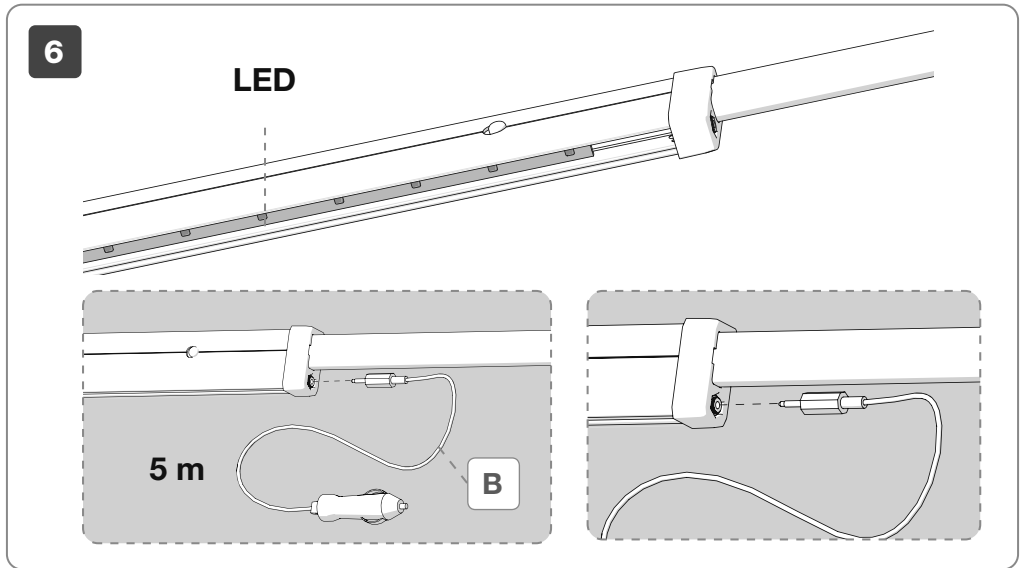

- EN** We remind you that the awning is a sun protection, so please close your awning in case of rain, wind or snow. Otherwise, please take the following precautions: lower one side of your awning, so that water can flow away and place the Rafter.
- DE** Eine Markise ist ein Sonnenschutz, deshalb muss sie bei kräftigem Wind, starkem Regen oder Schnee eingefahren werden! Andernfalls einen Stützfuß etwas heruntersetzen, damit das Wasser abfließen kann und die Spannstange Rafter.
- FR** Se rappeler que le store a été conçu comme protection du soleil et, de ce fait, il doit être fermé en cas d'intempéries (vent, pluie ou neige). Dans le cas contraire, abaisser un pied d'un côté pour faire écouler l'eau et monter le tendeur de toile Rafter.
- ES** El toldo ha sido concebido para repararse del sol y se aconseja cerrarlo en caso de viento, lluvia o nieve. Diversamente, tomar las debidas precauciones, bajando una pata para que el agua fluya y montando el Rafter.
- IT** Ricordare che il tendalino è stato concepito per ripararsi dal sole. Pertanto é consigliabile chiuderlo in caso di vento, pioggia o neve. Diversamente, abbassare una palina per permettere all'acqua di defluire e montare il Rafter.

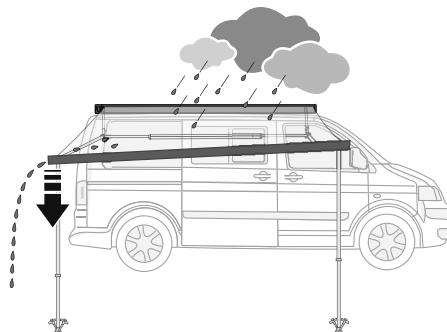



EN ATTENTION: we only suggest a temporary use of the tension Rafter.

DE ACHAHTUNG: Wir empfehlen nur den zeitweiligen Gebrauch von der Rafter Spannstange.

FR ATTENTION: nous conseillons de utiliser le tendeur Rafter seulement temporairement.

ES ATENCION: nos aconsejamos una utilización temporal del Rafter

IT ATTENZIONE: il Rafter è consigliato solo per uso temporaneo.

EN Read the following instructions and warnings carefully; failure to observe these installation and usage instructions as well as the laws for driving in the relevant country may cause severe harm or damage for which the manufacturer declines all responsibility.

The product has been designed and manufactured exclusively for the illumination of recreational vehicles, is not suitable for the illumination of home environments.

We recommend connecting the power cable to the vehicle's cigarette lighter. Damage to the power cable can lead to abnormal operation of the product.

It is strictly forbidden to go around with the LED lights on; connect the power supply in order to inhibit current flow while the vehicle is running.

We do not recommend prolonged periods of viewing at close proximity of the LED strip.

The manufacturer will not be held responsible for claims for damages resulting from the following:

- Defective installation or connection of the product.
- Damage to the product caused by mechanical influences and overvoltage.
- Alterations on the device without the express authorization of the manufacturer.

DE Lesen Sie sich die folgenden Anweisungen und Warnhinweise sorgfältig durch. Die Nichtbeachtung dieser Montage- und Nutzungsvorschriften sowie der Bestimmungen der Straßenverkehrsordnung im Einsatzland kann zu schwerwiegenden Schäden führen, für die der Hersteller keine Verantwortung übernimmt. Das Produkt wurde ausschließlich für die Beleuchtung von Freizeitfahrzeugen entworfen und eignet sich nicht für die Beleuchtung von Wohnungsumgebungen.

Wir empfehlen, das Netzkabel an den Zigarettenanzünder des Fahrzeugs anzuschließen. Eine Beschädigung des Netzkabels kann zu einem fehlerhaften Betrieb des Geräts führen.

Es ist strengstens verboten, mit eingeschalteten Led-Leuchten zu fahren; schliessen Sie daher das Netzteil an, um den Stromfluss während der Fahrt zu unterbinden.

Wir raten davon ab, aus nächster Nähe lange in das Licht der LED-Leiste zu schauen.

Der Hersteller haftet nicht für Schadenersatzansprüche, die sich aus dem Folgenden ergeben:

- Fehlerhafte Installation oder fehlerhafter Anschluss des Produktes.
- Produktschäden verursacht durch mechanische Einflüsse und Überspannung.
- Änderungen am Gerät ohne ausdrückliche Genehmigung des Herstellers.



FR

Lire attentivement les instructions de montage suivantes. Le non-respect de ces conseils d'installation ou d'utilisation mais aussi des normes relatives au code de la route du pays dans lequel vous circulez peuvent causer de graves dommages qui ne pourront aucunement engager la responsabilité du fabricant. Ce produit a été conçu et réalisé exclusivement pour l'éclairage des véhicules de loisirs ; il ne convient pas pour un éclairage domestique.

Il est conseillé de connecter le câble d'alimentation à l'allume-cigare du véhicule. L'endommagement du câble d'alimentation peut impliquer un mal-fonctionnement du produit.

Il convient de rappeler qu'il est strictement interdit de rouler avec les lumières LED allumées ; effectuer le branchement de façon à bloquer l'alimentation pendant que le véhicule est en marche. Il est déconseillé de regarder de façon prolongée et de très près la bande à LED. La responsabilité du constructeur ne pourra être engagée pour des dommages dérivant :

- d'une mauvaise installation ou d'un mauvais branchement du produit
- de dégâts générés, à leur tour, par un problème mécanique ou une surtension
- des modifications apportées au dispositif sans l'autorisation expresse du constructeur

ES

Lea atentamente las siguientes instrucciones y advertencias; el incumplimiento de estas normas de montaje y uso y de las normas del código de circulación del país por el que se circula puede causar daños graves sobre los que el fabricante declina toda responsabilidad.

El producto se ha diseñado y producido exclusivamente para la iluminación de vehículos recreativos, no es adecuado para la iluminación de entornos domésticos.

Recomendamos conectar el cable de alimentación al encendedor de cigarrillos del vehículo. Los daños en el cable de alimentación pueden hacer que el producto no funcione correctamente.

Está estrictamente prohibido circular con las luces LED encendidas; conectar la fuente de alimentación para inhibir el flujo de corriente cuando el vehículo está en marcha.

Desaconsejamos la visualización prolongada y a corta distancia de la tira LED. El fabricante no se hará responsable de los reclamos por daños y perjuicios ocasionados por lo siguiente:

- Instalación o conexión defectuosa del producto.
- Daños al producto causados por influencias mecánicas y sobretensión.
- Alteraciones en el dispositivo sin la autorización expresa del fabricante.

IT

Leggere con attenzione le seguenti istruzioni e avvertenze; il mancato rispetto di queste norme di montaggio e utilizzo nonché delle normative del codice stradale del paese di circolazione possono causare gravi danni in ordine ai quali la ditta produttrice declina ogni responsabilità. Il prodotto è stato progettato e realizzato esclusivamente per l'illuminazione dei veicoli ricreazionali, non è adatto per l'illuminazione di ambienti domestici.

Si suggerisce di collegare il cavo di alimentazione all'accendisigari del veicolo. Il danneggiamento del cavo di alimentazione può comportare un funzionamento anomalo del prodotto.

Si ricorda che è severamente vietato circolare con le luci LED accese; collegare l'alimentazione in modo da inibire il flusso di corrente mentre il veicolo è in moto.

Si consiglia la visione prolungata e a distanza ravvicinata della striscia LED.

Il produttore non sarà ritenuto responsabile per richieste di danni derivanti da quanto segue:

- Installazione o connessione difettosa del prodotto.
- Danni al prodotto causati da influenze meccaniche e sovratensione.
- Alterazioni sul dispositivo senza espressa autorizzazione del produttore.



EU Declaration of Conformity (DoC)

Date 05/10/2022

We,

Company name: Fiamma S.p.A.
Postal address: Via San Rocco, 56
Postcode and city: Cardano al Campo – (Varese)
Telephone number: 0331/709111
E-mail address: fiamma@fiamma.it

Declare that the DoC is issued under our sole responsibility and belongs to the following product:

Apparatus model / Product: Lighting systems
Trademark: Fiamma
Model / Type:

98655-850	Rafter Led
98655-902	Rafter Led Caravanstore
98655-914	Led Awning Case
98655-915	Kit Led Awning Case 50
98655-848	Led Awning Light
98655-883	Led Garage Light
98655A884	Led Sensor Door Light
98655-607	Led Awning Light Gutter
98655-849	Awning Arms Led
98655-886	Led Step
98655-471	Kit Awning Led
98655Z040	Kit Led Strip Awning
98655Z051	Kit Led Strip Awning High Brightness
98655-885	Led Warning Solar
98655Z098	Kit Led F65 Eagle
98655Z099	Kit Led F45 Eagle
98655Z134	Rafter Led F40

The object of the declaration described above is in conformity with the relevant Union harmonisation legislation:

- 2014/30/EU Electro Magnetic Compatibility Directive (EMCD).
- 2014/35/EU Low Voltage Directive (LVD).
- 2011/65/EU Restriction of the use of certain hazardous substances Directive (RoHS Directive).
- 2012/1194EU Implementing Directive 2009/125/EC of the European Parliament and of the Council with regard to ecodesign requirements for directional lamps, light emitting diode lamps and related equipment.
- 2012/874/EU Supplementing Directive 2010/30/EU of the European Parliament and of the Council with regard to energy labelling of electrical lamps and luminaires.
- EN 60529 (1991) + A1 (2000) The IP code or Ingress Protection ratings are defined in international standard (IP grade 44)
- IEC 62471:2006 Photobiological safety of lamps and lamp systems.

The following harmonised standards and/or technical specifications have been applied

Quality System Manager
Cerutti Davide

EN Warranty Fiamma. In case of defects with regards to materials and manufacturing, the customer is entitled to the warranty in accordance with local laws and regulations of the country in which the product was purchased.

DE Garantie Fiamma. Im Falle einer Mangelhaftigkeit der Ware, kann der Verbraucher unter den erforderlichen Voraussetzungen gegenüber dem Verkäufer von dem Garantieanspruch zu den festgelegten Bedingungen gemäss den lokalen Rechtsvorschriften Gebrauch machen.

FR Garantie Fiamma. En cas d'un défaut de conformité du produit, le consommateur pourra faire valoir ses droits de recours en garantie selon les modalités prévues par les dispositions légales locales, pour autant que les conditions de recours soient satisfaites.

ES Garantía Fiamma. En caso de fallos o defectos de material y de fabricación, el cliente puede hacer valer la garantía de acuerdo con las leyes y reglamentaciones del país en el que el producto haya sido comprado.

IT Garanzia Fiamma. In caso di difetto di conformità dei beni, il consumatore potrà far valere nei confronti del venditore la garanzia secondo le modalità previste dalle disposizioni di legge locali, ove ne ricorrano i presupposti.





fiamma.com

Fiamma S.p.A. - Italy

Via San Rocco, 56
21010 Cardano al Campo (VA)

All rights reserved.
Fiamma S.p.A.
reserves the right to modify at any time,
without notice, prices, materials,
specifications and models or to cease
production of any model.